



MODEL NO. TTSS9001

INSTRUCTION MANUAL VERSION 1.04

Thank you for choosing ORCA Products. Welcome to the power and convenience of Brushless RC. By purchasing the TTSS9001 Competition Brushless Electronic TOTEM Speed Control ("ESC") you have chosen one of the most advanced speed controls in RC Racing. The TTSS9001 allows customization for multiple programmable parameters and is the first ORCA speedo to have reverse polarity protection. Please read this manual thoroughly to familiarize yourself with the installation, setup and operation. By operating this product, you accept the ORCA Warranty Terms.

SPECIFICATION

*****REVERSE POLARITY PROTECTION*****
*****BUILT-IN CAPACITOR*****

System:	Brushless
Forward/Brake/Reverse:	Yes (Factory preset at Forward/Brake)
Dimensions:	25.8(L) x 33.6(W) x 17.6mm(H)
Weight:	23.5g (excluding wires)
Voltage Input:	6V-8.7V
Peak Current:	380A
Continuous current :	100A
Motor Limit:	Over 10.5Turns
Motor Type:	Sensored 540 sized brushless motors
B.E.C.:	4A_6V/7V
Multi Protection System:	Yes

INSTALLATION & CONNECTORS

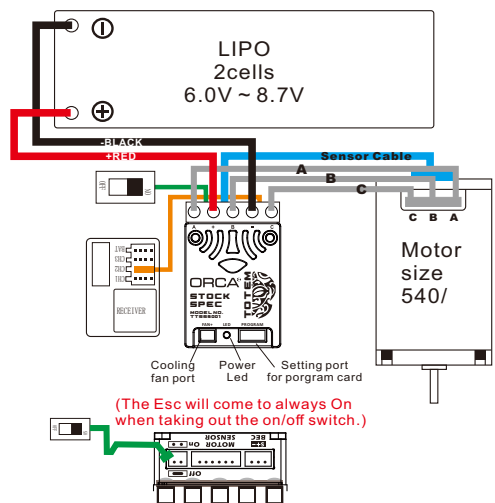

- Install/Solder the relevant battery connector (Battery Specific to the battery type. Red to +ve and Black to -ve. (The ESC has no response when reverse the +ve and -ve).
- Connect supplied BEC wire(200mm) to 3pin port match the (- + s) between the receiver connector and ESC.
- Connect the 3 motor wires to the motor; you can either solder the wires directly to the motor or use your favorite connectors. Match the label of the ESC Output (A, B, C) to the tab labels on the motor when soldering. Avoid soldering each joint for longer than 5 seconds. Period to operation, make sure you have not created a short by either creating a wire bridge or solder bridge on the solder tabs on the motor. (WARNING! Improper wiring may damage the ESC and void the warranty.)
- Connect the sensor cable between the ESC sensor plug and the Motor sensor plug.
- Connect the receiver plug to the CH2/throttle pin of the receiver.
- The Fan port voltage is drawn directly from the battery. (WARNING!) Improper configuration may damage the ESC.)

RADIO & Esc SETUP

Transmitter Settings:
 Throttle Travel Maximum / 100%
 Brake Travel Maximum / 100%
 Throttle Exponential Start with 0%
 Throttle Neutral Trim Center / 0
 Throttle Servo Reverse Reverse (Futaba, KO, Sanwa)
Initial set-up of the throttle end-points of the ESC:
 * Connect the power wires of the ESC to a fully charged battery set; making sure the polarity is correct.
 * Bind your receiver and transmitter first if your radio requires you to do so.
 * Turn on the transmitter and hold the throttle at full brake position.
 * Turn on ESC and listen for 2 beeps.
 * After you hear the 2 beeps, apply full throttle and listen for another 2 beeps.
 * Once you hear the 2 beeps, release the throttle to the neutral position.
 * A beep will then sound, signifying that the ESC endpoints have been successfully set.
 Note! If you do not hear the beeping sound as described above, try reversing the throttle reverse setting in the transmitter.

CUSTOMIZING THE Esc

Due to the different requirements of each style and class of racing, it is important to customize your ESC for each use case. Customization of the ESC is done using the Program Card (Sold Separately):

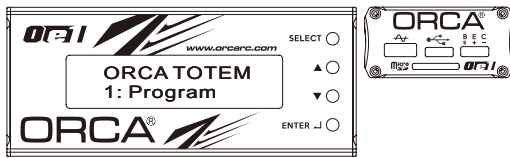

To begin, connect the battery wires to a charged battery, then connect supplied 4pin wire (200mm) to the ESC setting port (4pin port) and Program Card. Turn on the ESC and the Program Card will activate automatically. Note that the screen will show "Loading..." during initialization -indicating that the ESC is copying the current setup in the ESC to the Program Card. Once loading is completed, the screen will show "ORCA TOTEM" and "1. Program". You can now begin programming your ESC. Press "Enter" to access Program Mode.

TIPS! Whenever in doubt, double-check your ESC setting by initializing the Program Card again and checking each menu setting. Navigation around the Program Menu is done using the 4 buttons on the right-hand side of the Program Card. The function of each button varies depending on which screen the display is showing:
 "Select" button-----go to next select
 Press a H o l d "Select" button two second -----go to back page
 ▲ button - Scroll up
 ▼ button - Scroll down
 "Enter" button - Send Changes from Program Card to the ESC and overwrite old data in the ESC

NOTE! The Program Card is not included and is sold separately. The Program Card will compare the Parameters within the card and ESC before sending. If changes are detected, you will hear a series of beeps and the Program Card will display:



TIPS! Do not worry about making mistakes. You will not damage the ESC during setting. If in doubt, you can always reload the default setup and start over again.

OPERATION

Getting started
 Turn on the on/off switch, the screen will display:



Use "▲" button and "▼" button to find [Program], [Data Record] or [Update]. Press "▲" button to choose. Each mode presented is independent of the other and will require setup.

Press "SELECT" button for 2 seconds to go back to the previous screen.

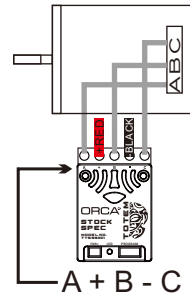
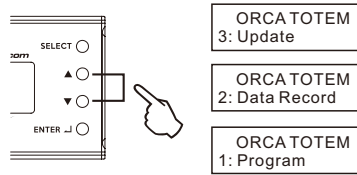

A+B-C must match the initial setup or match your programming setup. (WARNING! Improper configuration may damage the ESC.)

1. Program
 Enter direct go to setup page, 1:RunningMode Forward/Brake

Use "SELECT" button go to next setup item "2:BatteryCutOff" or "3:Punch or 4-10.

2. Data Record

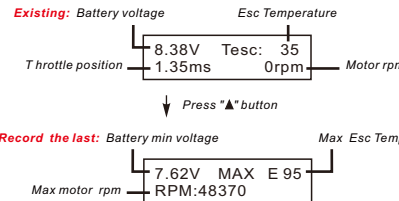

Double press "Enter" button to clear the data, otherwise Min and Max data will keep Forever.

3. Update

Updating of ESC Firmware:
 * Scroll to the "Update" menu and press "Enter". This will show the current ESC Firmware Version.
 * Press "Enter" again to access the SD cards FIRMWARE folder. Select the firmware. Version that you would like to use to update the ESC. Press "Enter" again and the update will commence (It will take around 1 minute to complete the update).

Updating of Program Card Firmware:
 * Depress and hold the Program card "Enter" button while turning on the ESC. It will display the current Program card firmware Version.
 * Press "Enter" again to access the SD cards Firmware folder. Select the Firmware Version that you would like to use to update the Program Card. Press "Enter" again and the update will commence (It will take around 1 minute to complete the update).

Preparing the SD card for use:
 Format a microSD card using FAT32 file structure using a personal computer. If you are using a Micro SD Card larger than 32GB, you will need to use a 3rd party SW Package to do this. Create a new folder called "FIRMWARE". Download the latest firmware from www.orcarc.com/firmware/ and copy the file to the "Firmware" folder on the Micro SD card. Once completed, install the MicroSD card into the microSD card slot of the Program Card. Both the Program Card and ESC Firmware Files need to be copied in to the "Firmware" Folder. A maximum of 10 of each ESC/Program card firmware can be present in the folder at any one time.

OPERATING TIPS

Multi-Protection System -- In addition to the Low Voltage and Overheat Protection that was described above, the ESC is protected in 2 more ways.

ESC auto temperature protect
 * The esc will auto down power to 50% when the esc temperature over 125F degree

Motor Lock Protection:
 * The motor not have temperature protection in this esc. but the ESC is protected against damage when the motor is stuck and does not turn at all. Power will not be applied in this situation.
 * CAUTION! Since the ESC relies on the feedback of the 3 motor wires to deploy this protection, it ONLY works if the motor does not turn AT ALL. If the rotor has any rotation, the ESC will consider the motor to be operational and the power to the motor will not be cut off.

Fail Signal Protection:
 * In case the radio signal to the ESC is interrupted for over 1 second during a run, the ESC will cut off until the signal resumes.

Misc. Tips:
 * Connect the ESC to the battery pack only when you are ready to run. This will avoid draining the battery pack. Always disconnect the battery after your run.
 * A tiny spark may occur when the battery is initially connected to the ESC. This is normal and is due to the charging of the capacitors.

All ORCA products are manufactured in accordance with the highest quality standards. ORCA guarantees this product to be free from defects in materials or workmanship for 60 days from the original date of purchase verified by sales receipt. This limited warranty does not cover damages resulting from abnormal wear, misuse or improper maintenance of the product.

To avoid unnecessary service and mailing charges, always eliminate all other possibilities and check all components for malfunctions before sending in your unit for repair. Products sent in for repair that operates ideally will be charge a service fee.

When sending in the product, pack carefully and include the original sales receipt, a description of the problem encountered, your return address and contact information. Since we do not have control over the installation and use of this product, we cannot accept any liability for any damages resulting from the usage of this product. Therefore, using this product is at your own risk, and the user accepts all resulting liability from installing and using the product.

Setting by Program Card

PROGRAM
A + B - C
C + B - A

↓ Press "Enter" button ↓

Press "Select" button to next function

1. Running Mode	Forward/Brake Forward/Rev For/Brake/Rev	Forward/Brake
2. Battery Cut Off	Lipolymer Low 2.9VMiddle 3.2VHigh 3.4V Disabled	Middle
3. Punch	1-5	5
4. PWM	1000 4000 8000 12000 16000 24000	8000
5. Drag Brake	Off 5% 10% 20% 30% 40% 50% 70% 85% 100%	Off
6. Max Brake Force	off 20% 40% 60% 80% 100%	100%
7. Brake Punch	1-5	5
8. Brake PWM	400Hz 600Hz 800Hz 1000Hz 2000Hz 4000Hz	1000Hz

Press "Select" button to next function

9. Reverse Force	25%	50%
	50%	
	75%	
	100%	
10. Neutral Range	3%	6%
	6%	
	9%	
	12%	
11. BEC Voltage	6V	6V
	7V	
12. Motor Action	CCW	CCW
	CW	
13. RPM Limit	Disabled	Disabled
	17500Rpm/2polo	
Load & Save	Load Deault	
	Load Custom 1	
	Load Custom 2	
	Save Custom 1	
	Save custom 2	

Detailed Explanation of each Function items:

- 1) Running Mode**
 Forward/Brake-----This function the car will not have reversed function, Just forward and brake.
 Forward/Rev----- This function the car will reverse immediately when the throttle brake the car.
 Forward/Brk/Rev--- Set this function the first the touch of throttle brake the car will have brake function, and if you release to center position after brake and continue brake again the reverse function will appear.
- 2) Battery Cut off Voltage**
 Lipolymer Low-----Lipo cut off at 2.9V/cell
 Lipolymer Middle -----Lipo cut off at 3.2V/cell
 Lipolymer High-----Lipo cut off at 3.4V/cell
- 3) Punch**
 Allows you to change the punch of the ESC (Level 1 to Level 5):
 * Level 1 has the least punch and Level 5 has the highest punch.
 * Adjust punch level to maximize acceleration speed with minimum wheel spin.
- 4) PWM(Driver Freq)**
 Allows you to change the forward drive frequency of the ESC (1K to 24K From six step)
 * The 1K setup will give you good punch at the low end.
 * The 24K setup will result in strong mid to top end.
 * Experiment to find out what suits your driving style best.

- 5) Drag Brake**
 Set the automatic brake force applied when the throttle returns to the neutral position (10 steps from Off to 100%):
 * 70%, 85% and 100% Drag Brake recommend used in Crawl only.
 - 6) Max Brake Force**
 Control the Maximum Brake power when you full braking
 - 7) Brake Punch**
 When you set Punch 5, the brake time will follow your throttle brake simple and direct, if you used Punch 1-4 the brake feeling have something ABS, get more smooth.
 - 8) Brake PWM(Brake Freq)**
 Brake PWM operates similarly to PWM except it affects the braking instead of the throttle (6 steps from 400hz to 4khz)
 * At 400 Hz, the Drag brake and the Brake force will feel the punchiest.
 * At 4k Hz, the Drag brake and the Brake will feel smooth.
 - 9) Max Reverse Force**
 Control the Maximum Reverse power when you Reverse the car.
 - 10) Neutral Range**
 Set the sensitive relay to your throttle feeling, normally set in "6%".
 - 11) BEC Voltage**
 Set the voltage 6V or 7V supply for the receiver, this is relay to your serval action feeling, normally set in "6V".
 - 12) Motor Action**
 Set the motor rotate direction, normally set in "CCW".
 - 13) PRM Limit**
 This function will limit your motor RPM maximum up to 17500rpm when using the 2-polar motor, normally set in "Disabled".
- Load & Save**
 This is a memory function, here has one deault setting and two custom space for easy memory your setup.